



Product Description

Available with a wide range of different instruments for safe operation due to the incorporated pressure regulator with integrated filter system mounted on a plate or in housing. For operating pressures up to 12 bar (174 PSI).

Technical Features

Gas supply systems GPS are specially designed for contact-free operation for gas-lubricated mechanical seals. The gas supplied from the supply network (e.g., air or nitrogen) is regulated/monitored by the GPS in accordance with the requirements of the gas seals. The GPS systems are equipped with alarm and/or switch-off points depending on specific safety requirements. Circulation in accordance with API 682/ISO 21049: Plan 74

Functional Description

GPS is a pressurize plan 74 which uses gas (e.g. Nitrogen) as a barrier medium for gas lubricated mechanical seals. The barrier gas pressure, p_3 must always be higher than the medium pressure, p_1 . For individual seal types, the minimum pressure difference (Δp) is specified separately.

Main GPS functions

- Filtering of barrier gas
- Pressure monitoring and regulation
- Flow monitoring

Typical tasks for the GPS

- Barrier gas supply for double seals
- Gas flushing for single seals
- Gas supply for tandem seals

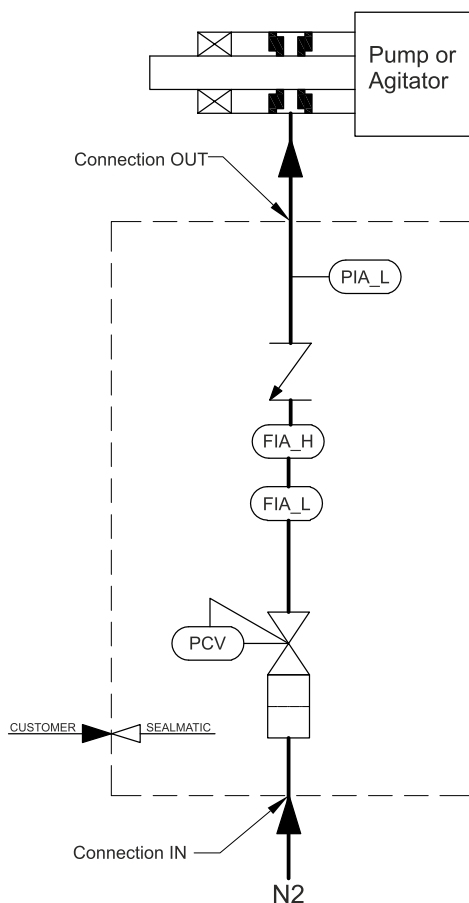

Advantages

- GPS System mounted in a housing or can be mounted on a plate
- Different instruments with wide scope available for safe operation

Recommended application

- Chemical industry
- Petrochemical industry
- Power plant technology
- Refining technology
- Oil and gas industry

Technical Data

Designation	GPS
Max. Operating Pressure	12 bar (174 PSI)
Max. Operating Temperature	60°C
Medium	Nitrogen / Air

PCV Pressure control valve
 FIA L: Flow meter with MIN Contact
 FIA H: Flow meter with MAX Contact
 PIA L: Pressure Gauge

Note: To assure a sufficient supply of the mechanical seal, pressure at entry of the supply system must be min. 2 bar (29 PSI) above max. barrier pressure always.