



### Product Description

Circulation in accordance with API 682 / ISO 21049: Plan 21, Plan 22, Plan 23, Plan 41  
 HED designed heat exchanger is employed to cool process/barrier fluids in seal supply systems.  
 Construction of the vessel is in a tubular design with integrated guide plates, the process/barrier medium is directed through the shell of the HED and the cooling medium through the tubes.

### Technical Features

1. Cooling capacity up to 36 kW
2. Installation can be done either in a vertical or a horizontal position
3. For optimum and simple cleaning, the heat exchanger can be dismantled
4. Compact design of tubular heat exchanger with integrated guide plates along with extremely efficient cooling capacity
5. Designed for varied applications due to construction in stainless steel allows flush with a suitable solvent on the process/barrier medium side

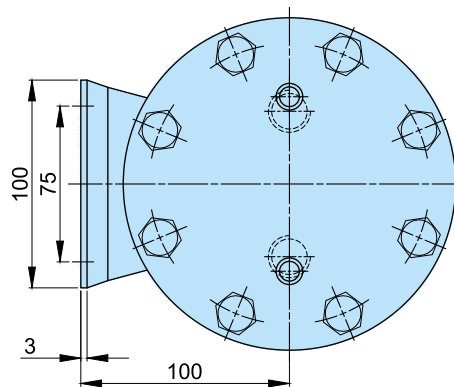
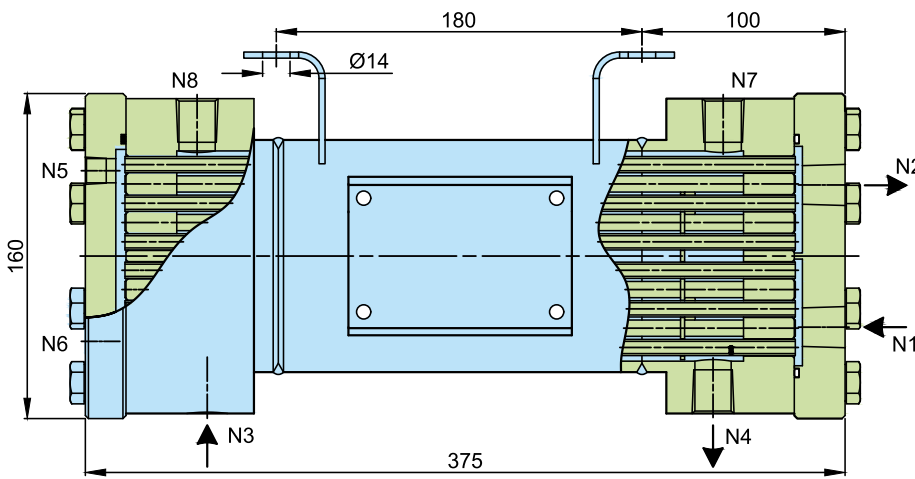

Connections	
Item	Description
N1	Cooling water IN
N2	Cooling water OUT
N3	Process/barrier medium IN
N4	Process/barrier medium OUT
N5	Cooling circuit vent
N6	Cooling water drain
N7/N8	Process/barrier circuit vent

Other versions on request.

<sup>1</sup>These values are based on the calculation of strength.

<sup>2</sup>These values are based on the calculation of heat.

<sup>7</sup>Related to water on both sides

### Typical Industrial Applications

- Chemical industry
- Oil and gas industry
- Petrochemical industry
- Power plant technology
- Refining technology

### Notes

Cleaning:  
 Cooling water side: the area around the tubes can be cleaned mechanically after the housing is removed.  
 Process/barrier medium side: flush with a suitable solvent.

### Standards

PED 2014/68/EU (Design and production in accordance with EU Pressure Equipment Directive)  
 ASME VIII, Div. 1 (Design, calculation and production)

### Technical Features

Designation HED	Tubes	Shell
Pressure Equipment Directive	PED	
Allowable pressure <sup>1</sup>	16 bar (232 PSI)	130 bar (1885 PSI)
Allowable temperature <sup>1</sup>	150 °C (302 °F)	
Inlet temperature <sup>2</sup>	30 °C (86 °F)	
Flow quantity (m <sup>3</sup> /h) <sup>7</sup>	1	
Volume (litres)	0.23	60 °C (149 °F)
Cooling surface <sup>2</sup>	0.2	
Cooling capacity (kW) <sup>7</sup>	6	
Metal parts	SS 316	approx. 0.5
O-rings	FKM	1.4
Gaskets	PTFE	
Screws	Stainless steel A4-70	